

DRAWN BY: PAUL FRENCH

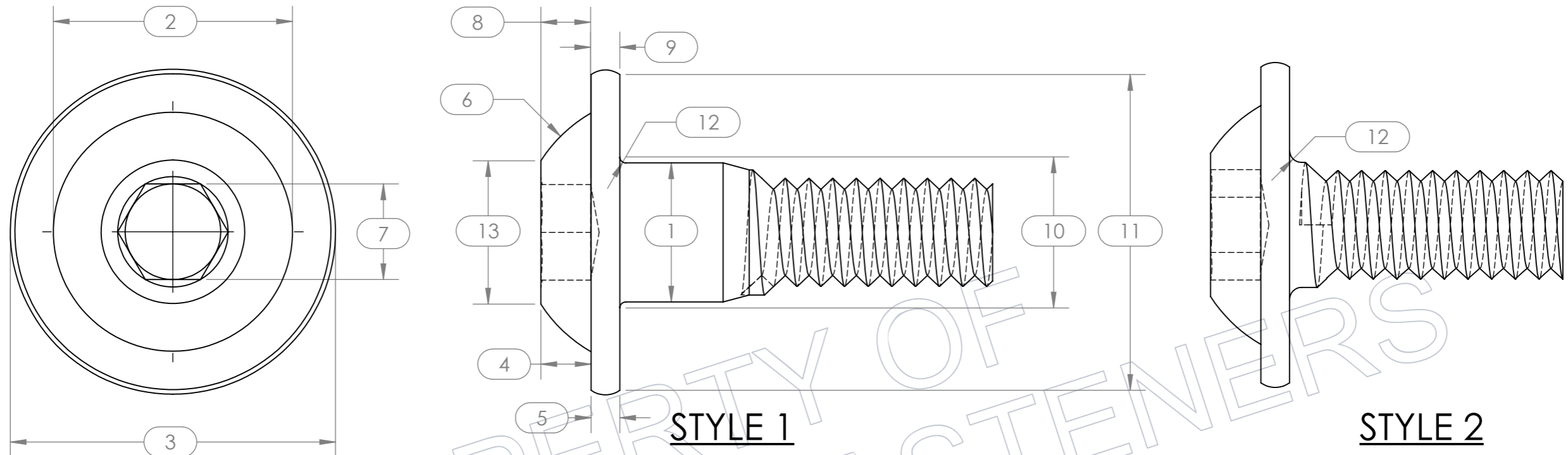

	1		2		3		4		5		6		7	8	9	10	11	12	
	GRIP DIAMETER		HEAD DIAMETER		WASHER DIAMETER		HEAD HEIGHT		WASHER HEIGHT		HEAD RADIUS		RECESS	RECESS DEPTH	WALL THICKNESS	FILLET DIA	BEARING SURFACE	U/HEAD RADIUS FT	U/HEAD RADIUS NOT FT
	MAX	MIN	MAX	MIN	MAX	MIN	MAX	MIN	MAX	MIN	MAX	MIN	NOM	MIN	MIN	MAX	MIN	MIN	MIN
M3	0.1181	0.1126	0.204	0.193	0.271	0.249	0.064	0.056	0.027	0.022	0.145	0.130	2MM (.0787)	0.041	0.008	0.141	0.226	0.012	0.004
M4	0.1574	0.1504	0.283	0.268	0.370	0.348	0.086	0.077	0.031	0.026	0.181	0.166	2.5MM (.0984)	0.052	0.012	0.185	0.325	0.016	0.008
M5	0.1968	0.1898	0.346	0.331	0.464	0.438	0.108	0.099	0.039	0.032	0.226	0.207	3MM (.1181)	0.062	0.015	0.224	0.410	0.018	0.008
M6	0.2362	0.2292	0.393	0.378	0.535	0.508	0.129	0.119	0.047	0.040	0.242	0.223	4MM (.1574)	0.082	0.030	0.267	0.481	0.020	0.010
M8	0.3149	0.3063	0.519	0.504	0.700	0.674	0.173	0.162	0.059	0.050	0.312	0.294	5MM (.1968)	0.103	0.042	0.362	0.646	0.028	0.016
M10	0.3937	0.3851	0.649	0.634	0.862	0.830	0.216	0.205	0.078	0.067	0.385	0.363	6MM (.2362)	0.123	0.058	0.440	0.797	0.028	0.016
M12	0.4724	0.4619	0.763	0.745	1.023	0.991	0.259	0.246	0.094	0.083	0.440	0.414	8MM (.3149)	0.164	0.065	0.539	0.958	0.044	0.024
M16	0.6299	0.6193	1.023	1.004	1.338	1.300	0.346	0.333	0.110	0.099	0.602	0.571	10MM (.3937)	0.205	0.089	0.696	1.260	0.044	0.024

*** DIMENSIONS TAKEN OUT OF ISO 7380-2: 2011 ***

PHONE: 623-925-5998

FAX: 623-925-5968

SALES@PARKERFASTENERS.COM

NOTE: ONLY ALLOY IS SPECIFIED AS A MATERIAL FOR THIS SPECIFICATION

NOTE: THREADS WILL BE 6g TOLERANCE

